

EXAMINED BY : <i>Yung Chang Hu</i>	EMERGING DISPLAY TECHNOLOGIES CORPORATION	FILE NO . CAS-51628
APPROVED BY:		ISSUE : JUN.11, 2009
<i>David Chang</i>		TOTAL PAGE : 22
		VERSION : 3

CUSTOMER ACCEPTANCE SPECIFICATIONS

MODEL NO. :

ET0350A6DM6

(RoHS)

FOR MESSRS :

CUSTOMER'S APPROVAL

DATE : _____

BY : _____

RECORDS OF REVISION

DOC . FIRST ISSUE

JUL.17, 2007

DATE

REVISED
PAGE
NO.

SUMMARY

JUN.04, 2008

0-3

12. SPECIFICATION OF AUDACITY ASSURANCE →
12. INSPECTION CRITERION

2

3.1 ELECTRICAL ABSOLUTE MAXIMUM RATINGS
POWER DISSIPATION : MAX.= (540) → 540
FORWARD CURRENT : MAX.= (25) → 25
REVERSE VOLTAGE : MAX.= (30) → 30

3

4. ELECTRICAL CHARACTERISTICS

PARAMETER	SYMBOL	CONDITION	MIN.	TYP.	MAX.	UNIT	REMARK
DIGITAL POWER SUPPLY	VCC	—	(2.5)	(3.3)	(3.6)	V	
ANALOG POWER SUPPLY	VDD	—	(2.5)	(3.3)	(3.6)	V	
DIGITAL OPERATING CURRENT	ICC	—	—	(1)	(2)	mA	
ANALOG OPERATING CURRENT	IDD	—	—	(10)	(15)	mA	
VCOM HIGH GRIFF VOLTAGE	VCOMH	—	—	—	(5.54)	V	
VCOM LOW GRIFF VOLTAGE	VCOML	—	VCOM+0.5	—	—	V	
FORWARD VOLTAGE	V _f	IF=20mA	(19.2)	(20.4)	(21.6)	V	

PARAMETER	SYMBOL	CONDITION	MIN.	TYP.	MAX.	UNIT	REMARK
DIGITAL POWER SUPPLY	VCC	—	2.5	3.3	3.6	V	
ANALOG POWER SUPPLY	VDD	—	2.5	3.3	3.6	V	
DIGITAL OPERATING CURRENT	ICC	—	—	1	2	mA	
ANALOG OPERATING CURRENT	IDD	—	—	10	15	mA	
VCOM HIGH GRIFF VOLTAGE	VCOMH	—	—	—	5.54	V	
VCOM LOW GRIFF VOLTAGE	VCOML	—	VCOM+0.5	—	—	V	
FORWARD VOLTAGE	V _f	IF=20mA	18	19.8	21.6	V	NOTE (1)

ADD NOTE (1), NOTE (2)

5

6.1 OPTICAL CHARACTERISTICS

ITEM	SYMBOL	CONDITION	MIN.	TYP.	MAX.	UNIT	REMARK
VIEWING ANGLE	θ _v	θ _v =0°	50	55	—	deg	(2), (3)
	θ _v	CR ≥ 10	170	175	—	deg	
		θ _v =0°	70	75	—	deg	
CONTRAST RATIO	CR	θ _v =0°, θ _y =0°	1550	(450)	—	—	(3)
RESPONSE TIME	t _r (ms)	θ _v =0°, θ _y =0°	—	15	20	ms	(4)
THE BRIGHTNESS OF MODULE	B	θ _v =0°, θ _y =0° (IF=20mA)	350	450	—	cd/m ²	(5)
COLOR OF CIE COORDINATE	WHITE	X	0.2350	0.2820	0.3320	—	(6)
	RED	Y	0.2611	0.3111	0.3611	—	
	GREEN	X	0.5621	0.6121	0.6621	—	
	BLUE	Y	0.3053	0.3553	0.4053	—	
	NTSC : 60%	X	0.2621	0.3121	0.3621	—	
THE UNIFORMITY OF BRIGHTNESS	—	—	(70)	—	—	%	—

ITEM	SYMBOL	CONDITION	MIN.	TYP.	MAX.	UNIT	REMARK
VIEWING ANGLE	θ _v	θ _v =0°	50	55	—	deg	(2), (3)
	θ _v	CR ≥ 10	70	75	—	deg	
		θ _v =0°	70	75	—	deg	
CONTRAST RATIO	CR	θ _v =0°, θ _y =0°	350	450	—	—	(3)
RESPONSE TIME	t _r (ms)	θ _v =0°, θ _y =0°	—	15	20	ms	(4)
THE BRIGHTNESS OF MODULE	B	θ _v =0°, θ _y =0° (IF=20mA)	350	450	—	cd/m ²	(5)
COLOR OF CIE COORDINATE	WHITE	W _x	0.236	0.286	0.336	—	(6)
	RED	W _y	0.261	0.311	0.361	—	
	GREEN	R _x	0.562	0.612	0.662	—	
	BLUE	R _y	0.305	0.355	0.405	—	
	NTSC : 60%	G _x	0.262	0.312	0.362	—	
THE UNIFORMITY OF BRIGHTNESS	—	—	70	—	—	%	—

NOTE (1) : 2° → 1°

6

6.2 THE TEST METHOD OF BRIGHTNESS AND UNIFORMITY

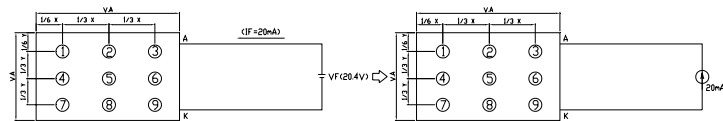

6.3 THE CALCULATING METHOD OF UNIFORMITY

$$\text{UNIFORMITY} = \left[1 - \frac{\text{MAXIMUM BRIGHTNESS} - \text{MINIMUM BRIGHTNESS}}{\text{AVERAGE BRIGHTNESS}} \right] \times 100\% \rightarrow$$

$$\text{UNIFORMITY} = \left[1 - \frac{\text{MAXIMUM BRIGHTNESS} - \text{MINIMUM BRIGHTNESS}}{\text{AVERAGE BRIGHTNESS}} \right] \times 100\%$$

12

11.1 POWER SUPPLY FOR LCM

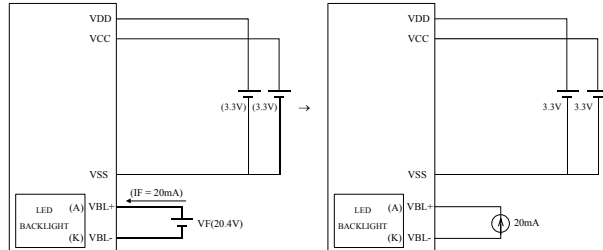

MODEL NO.	VERSION	PAGE
E T 0 3 5 0 A 6 D M 6 (RoHS)	3	0-2

RECORDS OF REVISION	DOC . FIRST ISSUE	JUL.17, 2007
---------------------	-------------------	--------------

DATE	REVISED PAGE NO.	SUMMARY
JUN.04, 2008	13	12. SPECIFICATION OF AUDACITY ASSURANCE → 12. INSPECTION CRITERION 12.2 INSPECTION CONDITIONS 30cm~40c → 30cm~40cm 12.2.4 INSPECTION METHOD (b)AQL : Major defect : AQL 0.65% → 0.65 Minor defect : AQL 1.0% → 1.0
	15~19	13.3.2 MODULE DEFECTS CALSSIFICATION REVISING THE ENTIRE PAGE
	20	NO.5 High temp / humidity test → High temp / humidity test storage NO.6 The sample should be allowed to stand the following 200 cycles of operation: -25°c for 30 minutes ~ +70°c for 30 minutes. → The sample should be allowed to stand the following 10 cycles of operation: -40°c for 30 minutes ~ +85°c for 30 minutes. NO.7 ESD(Electrostatic Discharge) → ESD(Electrostatic Discharge) (not operated) AIR DISCHARGE ± 4KV → AIR DISCHARGE ± 12KV CONTACT DISCHARGE ± 2KV → CONTACT DISCHARGE ± 8KV
	22	ADD 12.6.5
JUN.11, 2009	7	7. OUTLINE DIMENSIONS MARK △ : DELETE BARCODE LABEL

TABLE OF CONTENTS

NO.	ITEM	PAGE
1.	GENERAL SPECIFICATIONS -----	1
2.	MECHANICAL SPECIFICATIONS -----	1
3.	ABSOLUTE MAXIMUM RATINGS -----	2
4.	ELECTRICAL CHARACTERISTICS -----	3
5.	TIMING CHART -----	4
6.	OPTICAL CHARACTERISTICS -----	5, 6
7.	OUTLINE DIMENSIONS -----	7, 8
8.	BLOCK DIMENSIONS -----	9
9.	DETAIL DRAWING OF DOT MATRIX -----	10
10.	INTERFACE SIGNAL -----	11
11.	POWER SUPPLY -----	12
12.	INSPECTION CRITERION -----	13 ~ 22

1. GENERAL SPECIFICATIONS

1.1 APPLICATION NOTES FOR CONTROLLER/DRIVER
PLEASE REFER TO :

H X 8 2 3 8 - A

1.2 MATERIAL SAFETY DESCRIPTION

ASSEMBLIES SHALL COMPLY WITH EUROPEAN ROHS REQUIREMENTS, INCLUDING PROHIBITED MATERIALS/COMPONENTS CONTAINING LEAD, MERCURY, CADMIUM, HEXAVALENT CHROMIUM, POLYBROMINATED BIPHENYLS (PBB) AND POLYBROMINATED DIPHENYL ETHERS (PBDE)

2. MECHANICAL SPECIFICATIONS

(1) DISPLAY SIZE (inch)	-----	3.5"
(2) NUMBER OF DOTS	-----	320W * (RGB) * 240H DOTS
(3) MODULE SIZE	-----	76.8W * 63.8H * 3.3(D) mm (WITHOUT FPC)
(4) EFFECTIVE AREA	-----	71.08W * 53.56H mm
(5) ACTIVE AREA	-----	70.08W * 52.56H mm (LCD)
(6) DOT SIZE	-----	0.073W * 0.219H mm
(7) PIXEL SIZE	-----	0.219W * 0.219H mm
(8) LCD TYPE	-----	TFT , TRANSMISSIVE
(9) COLOR	-----	262K (8BIT)
(10) VIEWING DIRECTION	-----	6 O'CLOCK
(11) BACK LIGHT	-----	LED , COLOR : WHITE

3. ABSOLUTE MAXIMUM RATINGS

3.1 ELECTRICAL ABSOLUTE MAXIMUM RATINGS.

PARAMETER	SYMBOL	MIN.	MAX.	UNIT	REMARK
POWER VOLTAGE	VDD	VSS-0.3	5.0	V	—
	VCC	-0.3	4.0	V	—
POWER DISSIPATION	PD	—	540	mW	—
FORWARD CURRENT	IF	—	25	mA	—
REVERSE VOLTAGE	VR	—	30	V	—

3.2 ENVIRONMENTAL ABSOLUTE MAXIMUM RATINGS.

I T E M	OPERATING		STORAGE		REMARK
	MIN.	MAX.	MIN.	MAX.	
AMBIENT TEMPERATURE	-20°C	70°C	-30°C	80°C	NOTE (1), (2)
HUMIDITY	NOTE (3)		NOTE (3)		WITHOUT CONDENSATION
VIBRATION	—	2.45m/s ² (0.25G)	—	11.76m/s ² (1.2G)	5~20Hz , 1HR 20~500Hz(20Hz) , 1HR 20~500Hz(500Hz) , 1HR X,Y,Z,TOTAL 3HR
SHOCK	—	29.4m/s ² (3G)	—	490m/s ² (50G)	10 m SECONDS XYZ DIRECTIONS 1 TIME EACH
CORROSIVE GAS	NOT ACCEPTABLE		NOT ACCEPTABLE		

NOTE (1) : Ta AT -30°C : 48HR MAX.
80°C : 168HR MAX .

NOTE (2) : BACKGROUND COLOR CHANGES SLIGHTLY DEPENDING ON AMBIENT
TEMPERATURE THIS PHENOMENON IS REVERSIBLE .

NOTE (3) : Ta ≤ 60°C : 90%RH MAX (96HRS MAX).

Ta > 60°C : ABSOLUTE HUMIDITY MUST BE LOWER THAN THE HUMIDITY
OF 90%RH AT 60°C(96HRS MAX).

4. ELECTRICAL CHARACTERISTICS

Ta = 25 °C

PARAMETER	SYMBOL	CONDITION	MIN.	TYP.	MAX.	UNIT	REMARK
DIGITAL POWER SUPPLY	VCC	—	2.5	3.3	3.6	V	
ANALOG POWER SUPPLY	VDD	—	2.5	3.3	3.6	V	
DIGITAL OPERATING CURRENT	ICC	—	—	1	2	mA	
ANALOG OPERATING CURRENT	IDD	—	—	10	15	mA	
LOGIC HIGH OUTPUT VOLTAGE	VOH	I _{OUT} =-100μA	0.9*V _C	—	VCC	V	
LOGIC LOW OUTPUT VOLTAGE	VOL	I _{OUT} =100μA	0	—	0.1*V _C	V	
LOGIC HIGH INPUT VOLTAGE	VIH	H LEVEL	0.8*V _C	—	VCC	V	
LOGIC LOW INPUT VOLTAGE	VIL	L LEVEL	0	—	0.2*V _C	V	
VCOM HIGH OUTPUT VOLTAGE	VCOMH	—	—	—	5.54	V	
VCOM LOW OUTPUT VOLTAGE	VCOML	—	V _{CIM} +0.5	—	—	V	
FORWARD VOLTAGE	V _F	I _F =20mA	18	19.8	21.6	V	NOTE (1)
LED LIFE TIME		—	30k	40k	—	hr	

NOTE (1) : INTERNAL CIRCUIT DIAGRAM OF BACKLIGHT



NOTE (2) : AMBIENT TEMP .VS. ALLOWABLE FORWARD CURRENT.(PER LED)

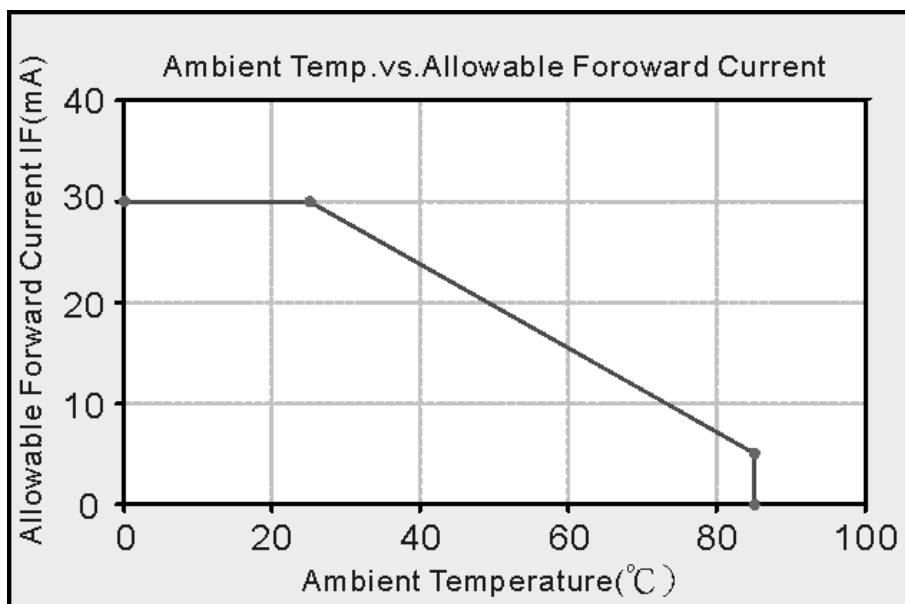

5. TIMING CHART

5.1 DIGITAL SERIAL RBG INTERFACE

CHARACTERISTICS	SYMBOL	MIN.	TYP.	MAX.	UNIT
DCLK FREQUENCY	fDCLK	—	19.5	30	MHz
DCLK PERIOD	tDCLK	33.3	51.3	—	ns
VERTICAL SYNC SETUP TIME	tvsys	10	—	—	ns
VERTICAL SYNC HOLD TIME	tvsyh	10	—	—	ns
HORIZONTAL SYNC SETUP TIME	thsys	10	—	—	ns
HORIZONTAL SYNC HOLD TIME	thsyh	10	—	—	ns
PHASE DIFFERENCE OF SYNC SIGNAL FALLING EDGE	thv	1	—	240	tDCLK
DCLK LOW PERIOD	tCKL	15	—	—	ns
DCLK HIGH PERIOD	tCKH	15	—	—	ns
DATA SETUP TIME	tds	10	—	—	ns
DATA HOLD TIME	tdh	10	—	—	ns
RESET PULSE WIDTH	tRES	10	—	—	μs

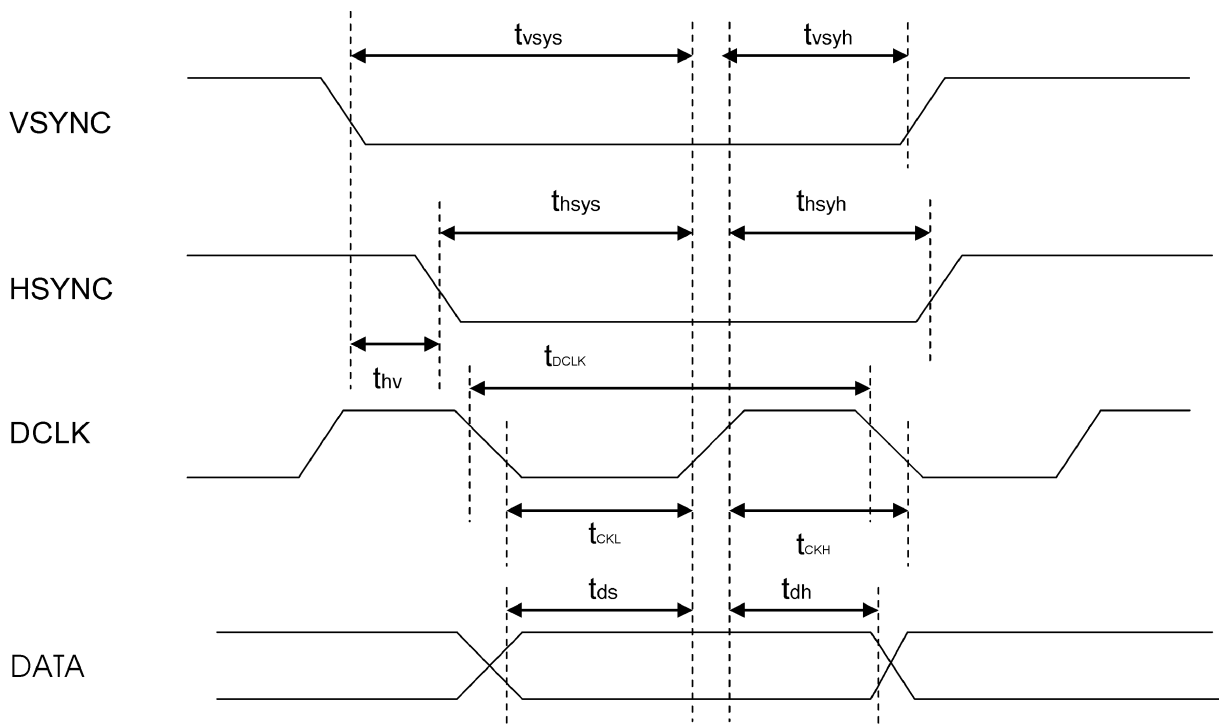

6. OPTICAL CHARACTERISTICS (NOTE1)
6.1 OPTICAL CHARACTERISTICS

Ta = 25 ± 2°C

I T E M		SYMBOL	CONDITION	MIN.	TYP.	MAX.	UNIT	REMARK	
VIEWING ANGLE		θ_{y+}	CR ≥ 10	50	55	—	deg.	(2), (3)	
		θ_{y-}		$\theta_x=0^\circ$	70	75			—
		θ_{x+}		$\theta_y=0^\circ$	70	75			—
		θ_{x-}			70	75			—
CONTRAST RATIO		CR	$\theta_x=0^\circ, \theta_y=0^\circ$	350	450	—	—	(3)	
RESPONSE TIME		T_R (rise)	$\theta_x=0^\circ, \theta_y=0^\circ$	—	15	20	msec	(4)	
		T_F (fall)		—	35	50			
THE BRIGHTNESS OF MODULE		B	$\theta_x=0^\circ, \theta_y=0^\circ$ IF=20mA	350	450	—	cd/m ²	(5)	
COLOR OF CIE COORDINATE	WHITE	Wx	$\theta_x=0^\circ, \theta_y=0^\circ$ IF=20mA NTSC : 60%	0.236	0.286	0.336	—	(6)	
		Wy		0.261	0.311	0.361			
	RED	Rx		0.562	0.612	0.662	—		
		Ry		0.305	0.355	0.405			
	GREEN	Gx		0.262	0.312	0.362	—		
		Gy		0.533	0.583	0.633			
	BLUE	Bx		0.090	0.140	0.190	—		
		By		0.020	0.070	0.120			
THE UNIFORMITY OF BRIGHTNESS		—	—	70	—	—	%	—	

NOTE (1) : TEST EQUIPMENT SETUP :

AFTER STABILIZING AND LEAVING THE PANEL ALONE AT A GIVEN TEMPERATURE FOR 30 MINUTES, THE MEASUREMENT SHOULD BE EXECUTED. MEASUREMENT SHOULD BE EXECUTED IN A STABLE, WINDLESS, AND DARK ROOM. OPTICAL SPECIFICATIONS ARE MEASURED BY TOPCON BM-7 (FAST) WITH A VIEWING ANGLE OF 1° AT A DISTANCE OF 50cm AND NORMAL DIRECTION.

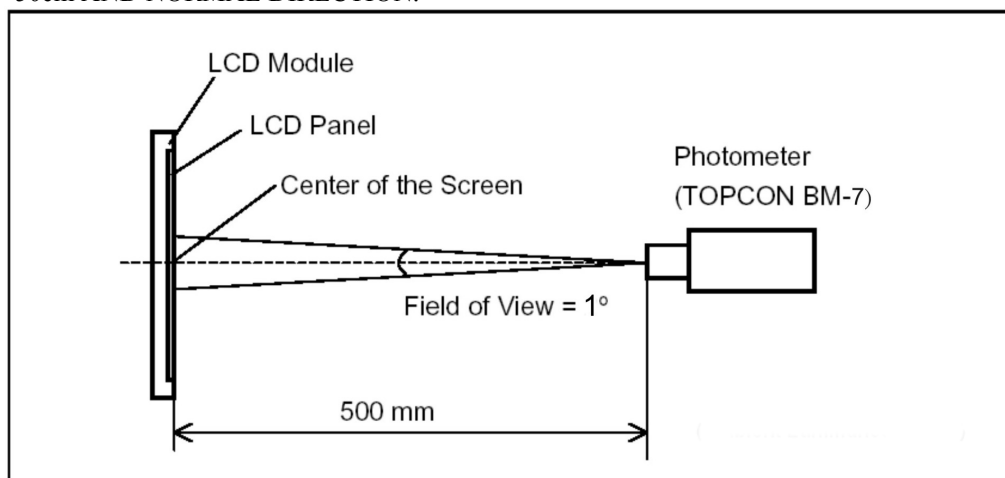

NOTE (2) : DEFINITION OF VIEWING ANGLE :

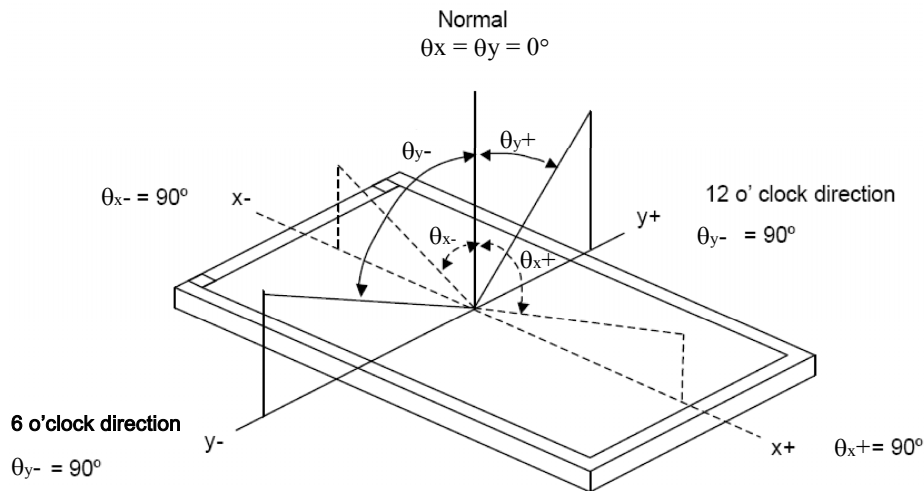

NOTE (3) : DEFINITION OF CONTRAST RATIO :

$$\text{CONTRAST RATIO (CR)} = \frac{\text{BRIGHTNESS MEASURED WHEN LCD IS AT "WHITE STATE"}}{\text{BRIGHTNESS MEASURED WHEN LCD IS AT "BLACK STATE"}}$$

NOTE (4) : DEFINITION OF RESPONSE TIME : TR AND TF

THE FIGURE BELOW IS THE OUTPUT SIGNAL OF THE PHOTO DETECTOR.

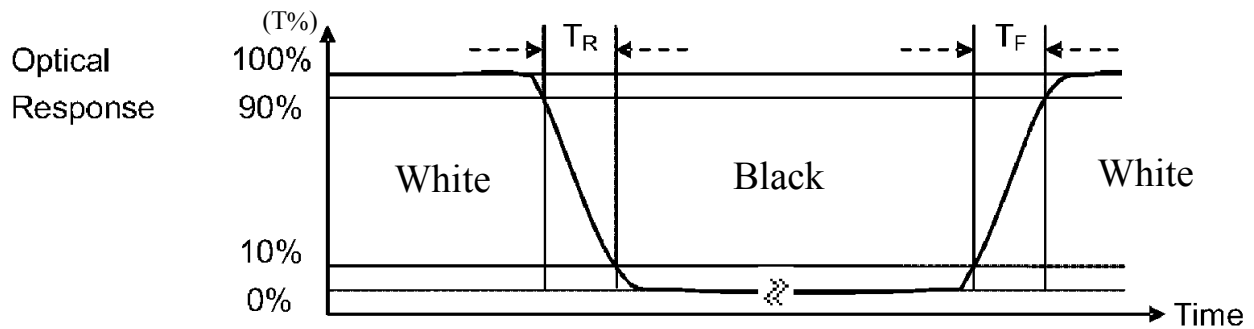

NOTE (5) : BRIGHTNESS MEASURED WHEN LCD IS AT " WHITE STATE"

NOTE (6) : THE 100% TRANSMISSION IS DEFINED AS THE TRANSMISSION OF LCD PANEL WHEN ALL THE INPUT TERMINALS OF MODULE ARE ELECTRICALLY OPENED.

6.2 THE TEST METHOD OF BRIGHTNESS AND UNIFORMITY

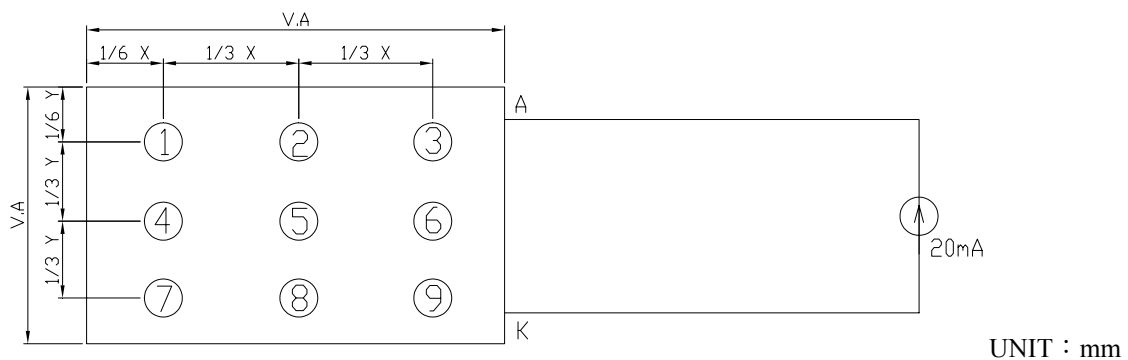

6.3 THE CALCULATING METHOD OF UNIFORMITY

$$\text{UNIFORMITY} = \left[1 - \frac{\text{MAXIMUM BRIGHTNESS} - \text{MINIMUM BRIGHTNESS}}{\text{AVERAGE BRIGHTNESS}} \right] \times 100\%$$

7. OUTLINE DIMENSIONS

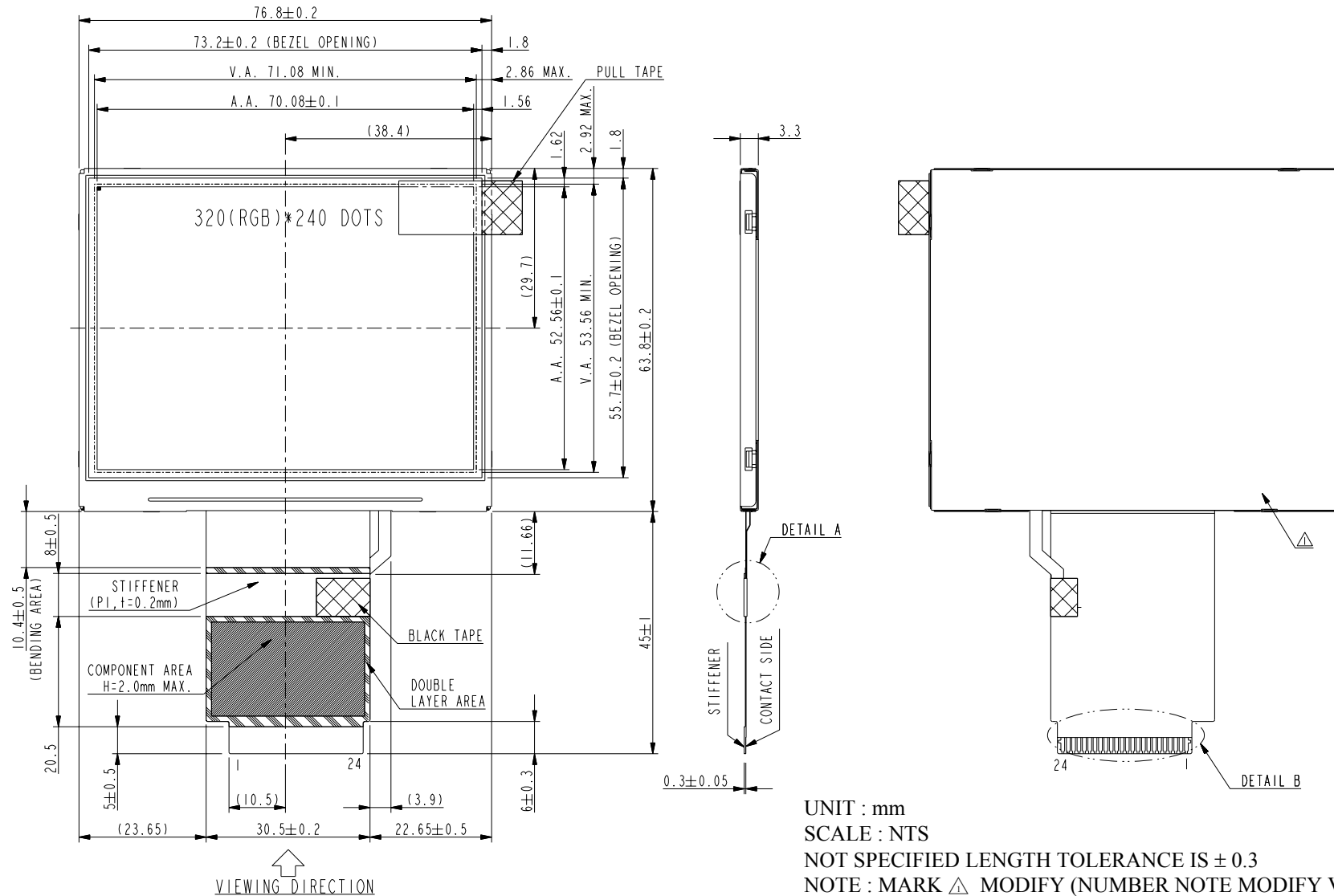

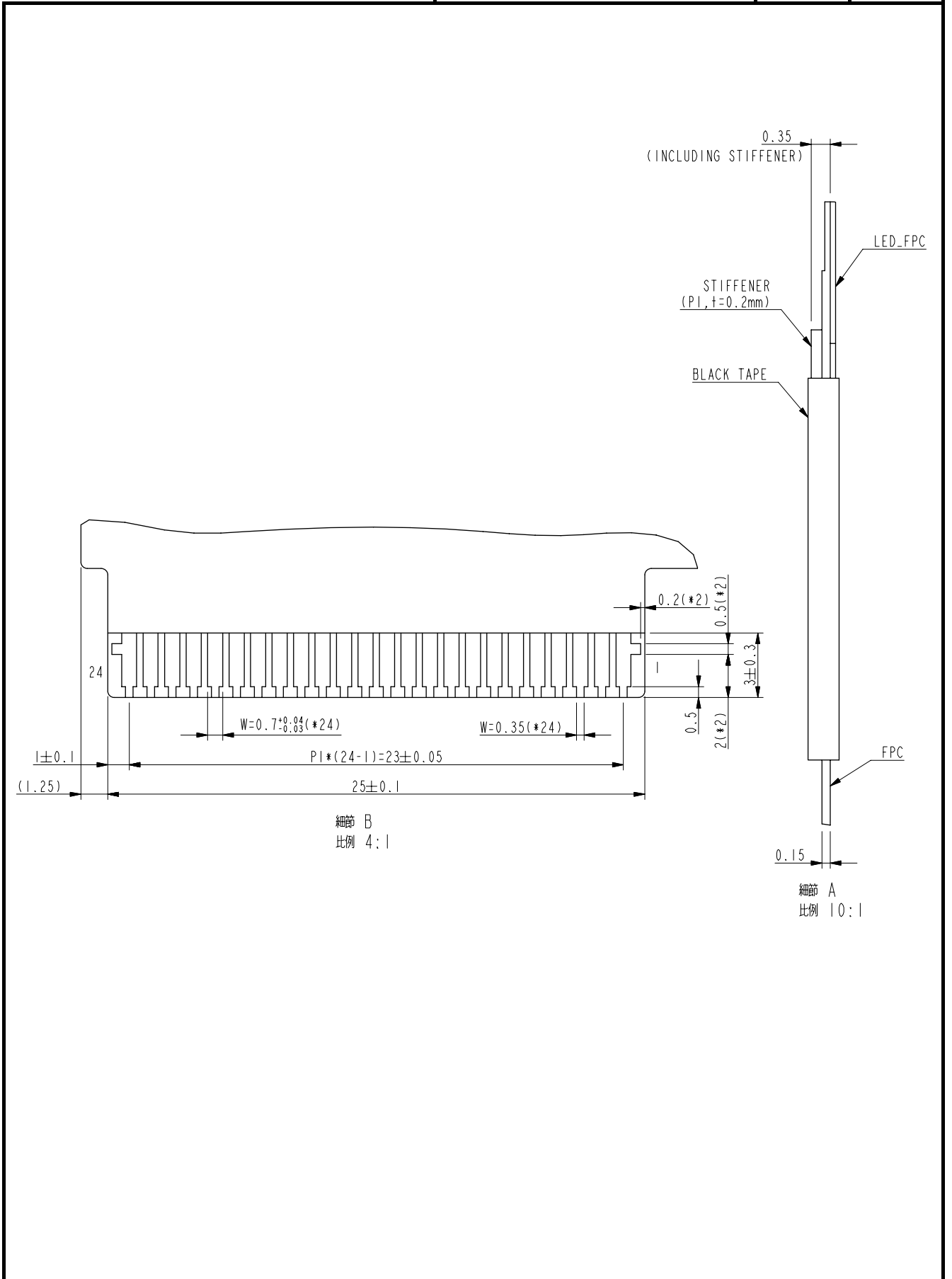

8. BLOCK DIMENSION

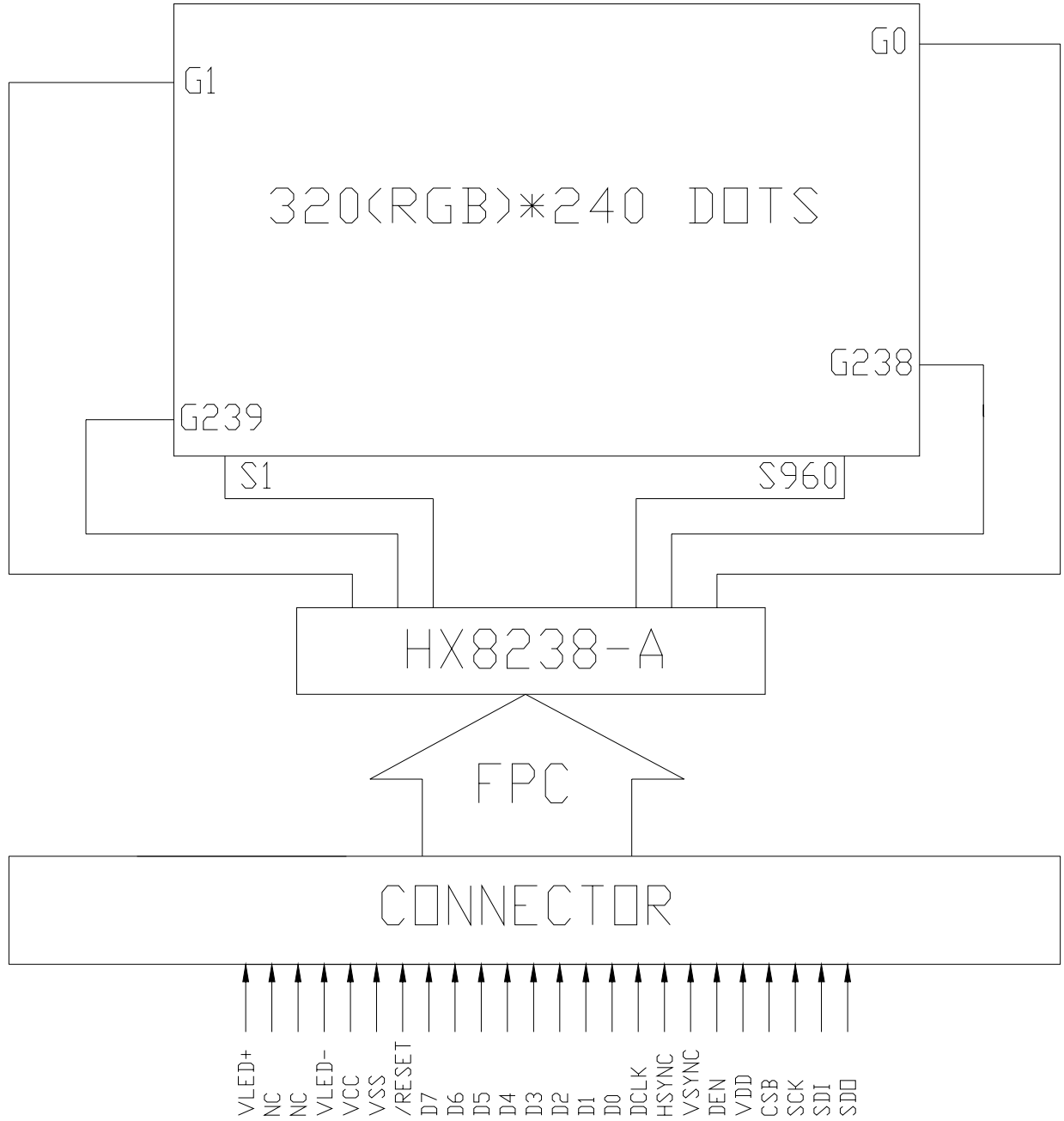

9. DETAIL DRAWING OF DOT MATRIX

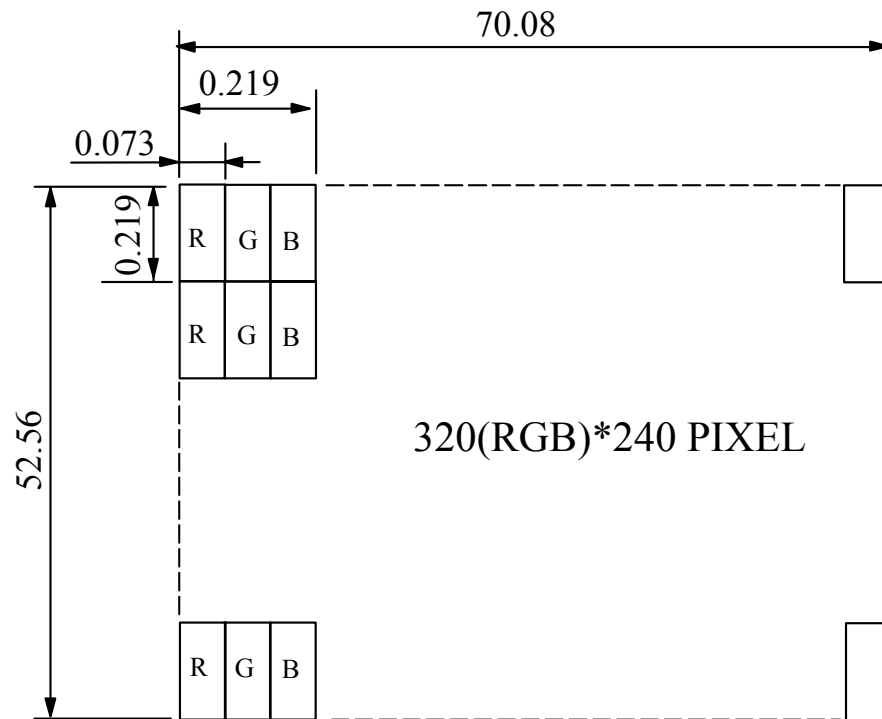

UNIT : mm
SCALE : NTS
NOT SPECIFIED TOLERANCE IS ± 0.1
DOTS MATRIX TOLERANCE IS ± 0.01

10. INTERFACE SIGNALS

PIN NO	SYMBOL	I/O	FUNCTION
1	VLED+	P	BACKLIGHT LED POWER (A)
2	NC	—	NOT USE
3	NC	—	NOT USE
4	VLED-	P	BACKLIGHT LED GROUND (K)
5	VCC	P	DIGITAL POWER (3.3V)
6	VSS	P	GROUND
7	/RESET	I	HARDWARE RESET
8	D7	I	DATA BIT 7
9	D6	I	DATA BIT 6
10	D5	I	DATA BIT 5
11	D4	I	DATA BIT 4
12	D3	I	DATA BIT 3
13	D2	I	DATA BIT 2
14	D1	I	DATA BIT 1
15	D0	I	DATA BIT 0
16	DCLK	I	DOT DATA COLCK
17	HSYNC	I	HORIZONTAL SYNC INPUT
18	VSYNC	I	VERTICAL SYNC INPUT
19	DEN	I	DATA ENABLE INPUT
20	VDD	P	ANALOG POWER (3.3V)
21	CSB	I	SPI INTERFACE CHIP SELECT BAR
22	SCK	I	SPI INTERFACE DATA CLOCK
23	SDI	I	SPI INTERFACE DATA (INPUT)
24	SDO	O	SPI INTERFACE DATA (OUTPUT)

1 1 . POWER SUPPLY
1 1 . 1 POWER SUPPLY FOR LCM

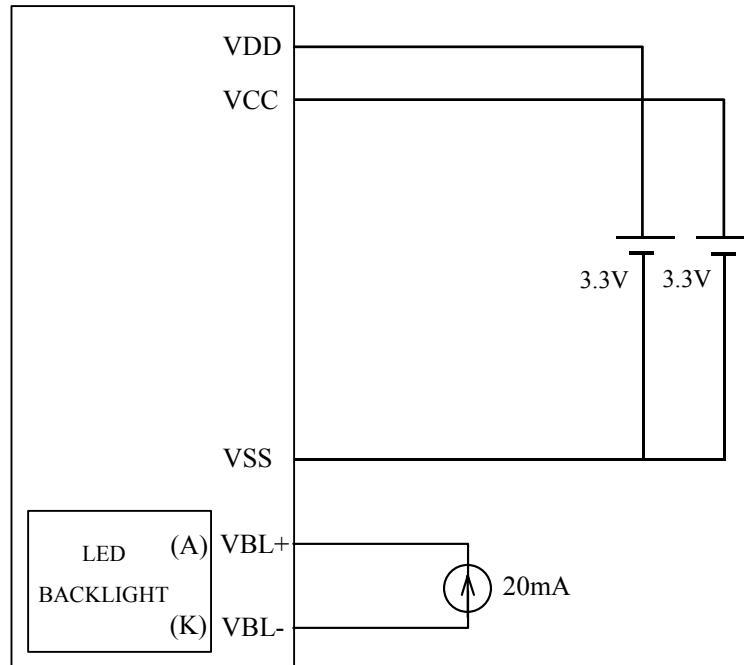

1 2 . INSPECTION CRITERION

12.1 APPLICATION

This inspection standard is to be applied to the LCD module delivered from EMERGING DISPLAY TECHNOLOGIES CORP.(E.D.T) to customers

12.2 INSPECTION CONDITIONS

12.2.1 (1)Observation Distance : 35cm±5cm

(2)View Angle :

Non-operation Condition : ±5°(perpendicular to LCD panel surface)

Operation Condition : ±45° (perpendicular to LCD panel surface)

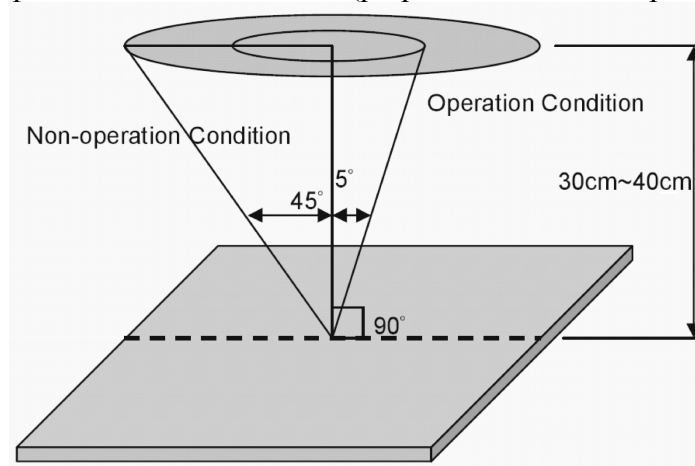

12.2.2 Environment Conditions :

Ambient Temperature		20°C~25°C
Ambient Humidity		65±20%RH
Ambient Illumination	Cosmetic Inspection	More than 600Lux
	Functional Inspection	300~500 Lux

12.2.3 Inspection lot

Quantity per delivery lot for each model

12.2.4 Inspection method

A sampling inspection shall be made according to the following provisions to judge The acceptability

(a)Applicable standard : MIL-STD-105E

Normal inspection, single sampling

Level II

(b)AQL : Major defect : AQL 0.65

Minor defect : AQL 1.0

12.3 INSPECTION STANDARDS

12.3.1 VISUAL DEFECTS CLASSIFICATION

TYPE OF DEFECT	INSPECTION ITEM	DEFECT FEATURE	AQL
MAJOR DEFECT	1.DISPLAY ON	<ul style="list-style-type: none"> • DEFECT TO MISS SPECIFIED DISPLAY FUNCTION, FOR ALL AND SPECIFIED DOTS EX: DISCONNECTION, SHORT CIRCUIT ETC 	0.65
	2.BACKLIGHT	<ul style="list-style-type: none"> • NO LIGHT • FLICKERING AND OTHER ABNORMAL ILLUMINATION 	
	3.DIMENSIONS	<ul style="list-style-type: none"> • SUBJECT TO INDIVIDUAL ACCEPTANCE SPECIFICATIONS 	
MINOR DEFECT	1.DISPLAY ZONE	<ul style="list-style-type: none"> • BLACK/WHITE SPOT • BUBBLES ON POLARIZER • NEWTON RING • BLACK/WHITE LINE • SCRATCH • CONTAMINATION • LEVER COLOR SPREED 	1.0
	2.BEZEL ZONE	<ul style="list-style-type: none"> • STAINS • SCRATCHES • FOREIGN MATTER 	
	3.SOLDERING	<ul style="list-style-type: none"> • INSUFFICIENT SOLDER • SOLDERED IN INCORRECT POSITION • CONVEX SOLDERING SPOT • SOLDER BALLS • SOLDER SCRAPS 	
	4.DISPLAY ON (ALL ON)	<ul style="list-style-type: none"> • LIGHT LINE 	

13.3.2 MODULE DEFECTS CALSSIFICATION

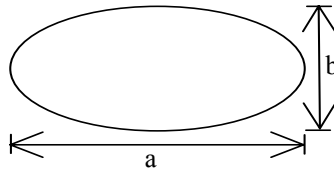
NO.	ITEM	CRITERIA												
1.	DISPLAY ON INSPECTION	(1)INCORRECT PATTERN (2)MISSING SEGMENT (3)DIM SEGMENT (4)OPERATING VOLTAGE BEYOND SPEC												
2.	OVERALL DIMENSIONS	(1)OVERALL DIMENSION BEYOND SPEC												
3.	DOT DEFECT	(1) INSPECTION PATTERN: FULL WHITE, FULL BLACK, RED, GREEN AND BLUE SCREENS. (2) <table border="1" style="margin-left: 20px;"> <thead> <tr> <th>ITEMS</th> <th>ACCEPTABLE COUNT</th> </tr> </thead> <tbody> <tr> <td>BRIGHT DOT</td> <td>N ≤ 2</td> </tr> <tr> <td>DARK DOT</td> <td>N ≤ 3</td> </tr> <tr> <td>TOAL BRIGHT AND DARK DOTS</td> <td>N ≤ 4</td> </tr> </tbody> </table> <p>NOTE :</p> <p>1. THE DEFINITION OF DOT : THE SIZE OF A DEFECTIVE DOT OVER 1/2 OF WHOLE DOT IS REGARDED AS ONE DEFECTIVE DOT.</p> <p>2. BRIGHT DOT : DOTS APPEAR BRIGHT AND UNCHANGED IN SIZE IN WHICH LCD PANEL IS DISPLAYING UNDER BLACK PATTERN.</p> <p>3. DARK DOT : DOTS APPEAR DARK AND UNCHANGED IN SIZE IN WHICH LCD PANEL IS DISPLAYING UNDER PURE RED, GREEN, BLUE PICTURE.</p>	ITEMS	ACCEPTABLE COUNT	BRIGHT DOT	N ≤ 2	DARK DOT	N ≤ 3	TOAL BRIGHT AND DARK DOTS	N ≤ 4				
ITEMS	ACCEPTABLE COUNT													
BRIGHT DOT	N ≤ 2													
DARK DOT	N ≤ 3													
TOAL BRIGHT AND DARK DOTS	N ≤ 4													
4.	FOREIGN BLACK/WHITE/ BRIGHT LINE/ SCRATCH OF VIEWING AREA	<table border="1" style="margin-left: 20px;"> <thead> <tr> <th>LENGTH : L</th> <th>WIDTH : W</th> <th>PERMISSIBLE NO.</th> </tr> </thead> <tbody> <tr> <td>$L \leq 0.3$</td> <td>$W \leq 0.05$</td> <td>IGNORE</td> </tr> <tr> <td>$0.3 < L \leq 2.5$</td> <td>$0.05 < W \leq 0.1$</td> <td>4</td> </tr> <tr> <td>$2.5 < L$</td> <td>$0.1 < W$</td> <td>NONE</td> </tr> </tbody> </table> <p>WIDTH : W mm, LENGH : L mm</p>	LENGTH : L	WIDTH : W	PERMISSIBLE NO.	$L \leq 0.3$	$W \leq 0.05$	IGNORE	$0.3 < L \leq 2.5$	$0.05 < W \leq 0.1$	4	$2.5 < L$	$0.1 < W$	NONE
LENGTH : L	WIDTH : W	PERMISSIBLE NO.												
$L \leq 0.3$	$W \leq 0.05$	IGNORE												
$0.3 < L \leq 2.5$	$0.05 < W \leq 0.1$	4												
$2.5 < L$	$0.1 < W$	NONE												
5.	FOREIGN MATTER \ BLACK SPOTS \ WHITE SPOTS \ DENT (INCLUDING LIGHT LEAKAGE DUE TO POLARIZING PLATES PINHOLES, ETC.)	<table border="1" style="margin-left: 20px;"> <thead> <tr> <th>AVERAGE DIAMETER (mm): D</th> <th>NUMBER OF PIECES PERMITTED</th> </tr> </thead> <tbody> <tr> <td>$D \leq 0.15$</td> <td>IGNORE</td> </tr> <tr> <td>$0.15 < D \leq 0.5$</td> <td>4</td> </tr> <tr> <td>$0.5 < D$</td> <td>NONE</td> </tr> </tbody> </table> <p>NOTE : DIAMETER $D=(a+b)/2$</p> 	AVERAGE DIAMETER (mm): D	NUMBER OF PIECES PERMITTED	$D \leq 0.15$	IGNORE	$0.15 < D \leq 0.5$	4	$0.5 < D$	NONE				
AVERAGE DIAMETER (mm): D	NUMBER OF PIECES PERMITTED													
$D \leq 0.15$	IGNORE													
$0.15 < D \leq 0.5$	4													
$0.5 < D$	NONE													

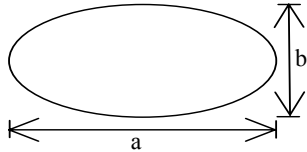
NO.	ITEM	CRITERIA		
			AVERAGE DIAMETER (mm) : D	NUMBER OF PIECES PERMITTED
6.	BUBBLES OF POLARIZER /DIRT/CF FAIL /SURFACE STAINS	BUBBLE ON THE POLARIZER	$D \leq 0.25$	IGNORE
			$0.25 < D \leq 0.5$	$N \leq 5$
			$0.5 < D$	NOTE
		SURFACE STATUS	$D < 0.1 \text{ mm}$	IGNORE
			$0.1 < D \leq 0.3\text{mm}$	$N \leq 3$
		CF FAIL / SPOT	$D < 0.1 \text{ mm}$	IGNORE
$0.1 < D \leq 0.3\text{mm}$	$N \leq 3$			
		<p>NOTE : (1)POLARIZER BUBBLE IS DEFINED AS THE BUBBLE APPEARS ON ACTIVE DISPLAY AREA. THE DEFECT OF POLARIZER BUBBLE SHALL BE IGNORED IF THE POLARIZER BUBBLE APPEARS ON THE OUTSIDE OF ACTIVE DISPLAY AREA.</p> <p>(2)THE EXTRANEIOUS SUBSTANCE IS DEFINED AS IT CAN BE OBSERVED WHEN THE MODULE IS POWER ON.</p> <p>(3)THE DEFINITION OF AVERAGE DIAMETER, D IS DEFINED AS FOLLOWING.</p> <p>AVERAGE DIAMETER (D)=(a+b)/2</p> 		
7.	LINE DEFECT ON DISPLAY	OBVIOUS VERTICAL OR HORIZONTAL LINE DEFECT IS NOT ALLOW		
8.	MURA ON DISPLAY	IT'S OK IF MURA IS SLIGHT VISIBLE THROUG 6% ND FILTER		
9.	UNEVEN COLOR SPREAD, COLORATION	(1)TO BE DETERMINED BASED UPON THE STANDARD SAMPLE.		
10.	BEZEL APPEARANCE	(1)BEZEL MAY NOT HAVE RUST, BE DEFORMED OR HAVE FINGER PRINTS STAINS OF OTHER CONTAMINATION. (2)BEZEL MUST COMPLY WITH JOB SPECIFICATIONS.		
11	PCB	<p>(1)THERE MAY NOT BE MORE THAN 2mm OF SEALANT OUTSIDE THE SEAL AREA ON THE PCB, AND THERE SHOULD BE NO MORE THAN THREE PLACES.</p> <p>(2)NO OXIDATION OR CONTAMINATION PCB TERMINALS.</p> <p>(3)PARTS ON PCB MUST BE THE SAME AS ON THE PRODUCTION CHARACTERISTIC CHART. THERE SHOULD BE NO WRONG PARTS, MISSING PARTS OR EXCESS PARTS.</p> <p>(4)THE JUMPER ON THE PCB SHOULD CONFORM TO THE PRODUCT CHARACTERISTIC CHART.</p> <p>(5)IF SOLDER GETS ON BEZEL TAB PADS, LED PAD, ZEBRA PAD OR SCREW HOLD PAD, MAKE SURE IT IS SMOOTHED DOWN.</p>		

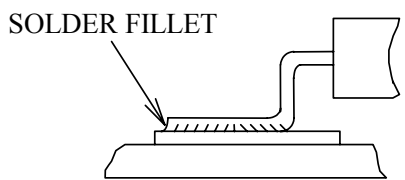
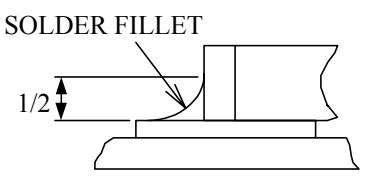
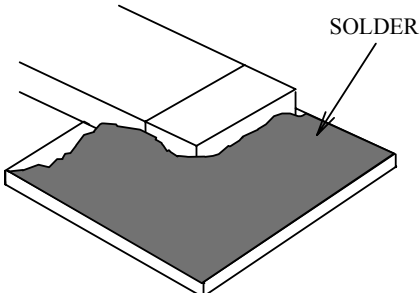
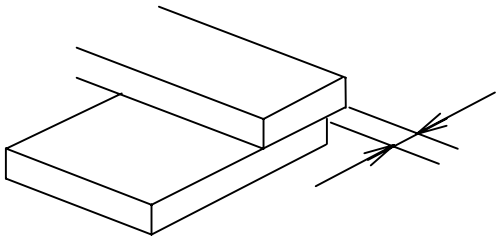
NO.	ITEM	CRITERIA
12.	SOLDERING	<p>(1) NO SOLDERING FOUND ON THE SPECIFIED PLACE</p> <p>(2) INSUFFICIENT SOLDER</p> <p>(a) LSI, IC A POOR WETTING OF SOLDER IS BETWEEN LOWER BEND OR "HEEL" OF LEAD AND PAD</p>  <p>(b) CHIP COMPONENT • SOLDER IS LESS THAN 50% OF SIDES AND FRONT FACE WETTING</p>  <p>• SOLDER WETS 3 SIDES OF TERMINAL, BUT LESS THAN 25% OF SIDES AND FRONT SURFACE AREA ARE COVERED</p>  <p>(3) PARTS ALIGNMENT</p> <p>(a) LSI, IC LEAD WIDTH IS MORE THAN 50% BEYOND PAD OUTLINE</p> 

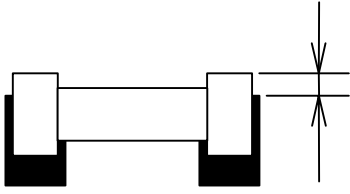
NO.	ITEM	CRITERIA
12.	SOLDERING	<p>(b)CHIP COMPONENT COMPONENT IS OFF CENTER, AND MORE THAN 50% OF THE LEADS IS OFF THE PAD OUTLINE</p>  <p>(4)NO UNMELTED SOLDER PASTE MAY BE PRESENT ON THE PCB. (5)NO COLD SOLDER JOINTS, MISSING SOLDER CONNECTIONS, OXIDATION OR ICICLE. (6)NO RESIDUE OR SOLDER BALLS ON PCB. (7)NO SHORT CIRCUITS IN COMPONENTS ON PCB.</p>
13.	BACKLIGHT	<p>(1)NO LIGHT (2)FLICKERING AND OTHER ABNORMAL ILLUMINATION (3)SPOTS OR SCRATCHES THAT APPEAR WHEN LIT MUST BE JUDGED USING LCD SPOT, LINES AND CONTAMINATION STANDARDS. (4)BACKLIGHT DOESN'T LIGHT OR COLOR IS WRONG.</p>
14.	GENERAL APPEARANCE	<p>(1)NO OXIDATION, CONTAMINATION, CURVES OR, BENDS ON INTERFACE PIN (OLB) OF TCP. (2)NO CRACKS ON INTERFACE PIN (OLB) OF TCP. (3)NO CONTAMINATION, SOLDER RESIDUE OR SOLDER BALLS ON PRODUCT. (4)THE IC ON THE TCP MAY NOT BE DAMAGED, CIRCUITS. (5)THE UPPERMOST EDGE OF THE PROTECTIVE STRIP ON THE INTERFACE PIN MUST BE PRESENT OR LOOK AS IF IT CAUSE THE INTERFACE PIN TO SEVER. (6)THE RESIDUAL ROSIN OR TIN OIL OF SOLDERING (COMPONENT OR CHIP COMPONENT) IS NOT BURNED INTO BROWN OR BLACK COLOR. (7)SEALANT ON TOP OF THE ITO CIRCUIT HAS NOT HARDENED. (8)PIN TYPE MUST MATCH TYPE IN SPECIFICATION SHEET. (9)LCD PIN LOOSE OR MISSING PINS. (10)PRODUCT PACKAGING MUST THE SAME AS SPECIFIED ON PACKAGING SPECIFICATION SHEET. (11)PRODUCT DIMENSION AND STRUCTURE MUST CONFORM TO PRODUCT SPECIFICATION SHEET. (12)THE APPEARANCE OF HEAT SEAL SHOULD NOT ADMIT ANY DIRT AND BREAK.</p>

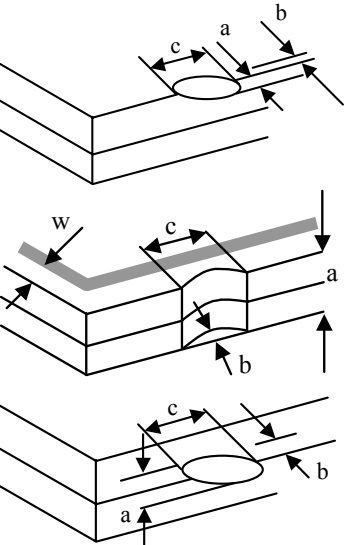
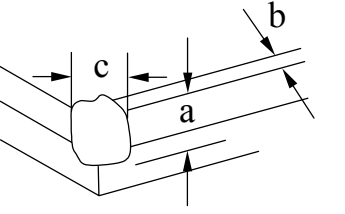
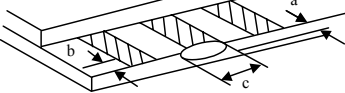
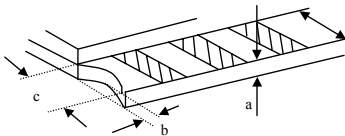
NO.	ITEM	CRITERIA										
15.	CRACKED GLASS	<p>THE LCD WITH EXTENSIVE CRACK IS NOT ACCEPTABLE</p>										
		<p>GENERAL GLASS CHIP :</p> 	<table border="1" data-bbox="935 416 1458 499"> <thead> <tr> <th>a</th> <th>b</th> <th>c</th> </tr> </thead> <tbody> <tr> <td>$\leq t/2$</td> <td>< VIEWING AREA</td> <td>$\leq 1/8X$</td> </tr> <tr> <td>$t/2 >, \leq 2t$</td> <td>$\leq W/2$</td> <td>$\leq 1/8X$</td> </tr> </tbody> </table> <p>*W=DISTANCE BETWEEN SEALANT AREA AND LCD PANEL EDGE X = LCD SIDE LENGTH t = GLASS THICKNESS</p>	a	b	c	$\leq t/2$	< VIEWING AREA	$\leq 1/8X$	$t/2 >, \leq 2t$	$\leq W/2$	$\leq 1/8X$
		a	b	c								
		$\leq t/2$	< VIEWING AREA	$\leq 1/8X$								
		$t/2 >, \leq 2t$	$\leq W/2$	$\leq 1/8X$								
<p>CORNER PART :</p> 	<table border="1" data-bbox="935 1005 1458 1088"> <thead> <tr> <th>a</th> <th>b</th> <th>c</th> </tr> </thead> <tbody> <tr> <td>$\leq t/2$</td> <td>< VIEWING AREA</td> <td>$\leq 1/8X$</td> </tr> <tr> <td>$> t/2, \leq 2t$</td> <td>$\leq W/2$</td> <td>$\leq 1/8X$</td> </tr> </tbody> </table> <p>*W=DISTANCE BETWEEN SEALANT AREA AND LCD PANEL EDGE X = LCD SIDE LENGTH t = GLASS THICKNESS</p>	a	b	c	$\leq t/2$	< VIEWING AREA	$\leq 1/8X$	$> t/2, \leq 2t$	$\leq W/2$	$\leq 1/8X$		
a	b	c										
$\leq t/2$	< VIEWING AREA	$\leq 1/8X$										
$> t/2, \leq 2t$	$\leq W/2$	$\leq 1/8X$										
<p>CHIP ON ELECTRODE PAD</p> 	<table border="1" data-bbox="935 1281 1458 1341"> <thead> <tr> <th>a</th> <th>b</th> <th>c</th> </tr> </thead> <tbody> <tr> <td>$\leq t$</td> <td>$\leq 0.5\text{mm}$</td> <td>$\leq 1/8X$</td> </tr> </tbody> </table> <p>* X=LCD SIDE WIDTH t=GLASS THICKNESS</p>	a	b	c	$\leq t$	$\leq 0.5\text{mm}$	$\leq 1/8X$					
a	b	c										
$\leq t$	$\leq 0.5\text{mm}$	$\leq 1/8X$										
	<table border="1" data-bbox="935 1435 1458 1496"> <thead> <tr> <th>a</th> <th>b</th> <th>c</th> </tr> </thead> <tbody> <tr> <td>$\leq t$</td> <td>$\leq 1/8X$</td> <td>$\leq L$</td> </tr> </tbody> </table> <p>*X=LCD SIDE WIDTH t = GLASS THICKNESS L=ELECTRODE PAD LENGTH ①IF GLASS CHIPPING THE ITO TERMINAL, OVER 2/3 OF THE ITO MUST REMAIN AND BE, INSPECTED ACCORDING TO ELECTRODE TERMINAL SPECIFICATIONS ②IF THE PRODUCT WILL BE HEAT SEALED BY THE CUSTOMER, THE ALIGNMENT MARK MUST NOT BE DAMAGED</p>	a	b	c	$\leq t$	$\leq 1/8X$	$\leq L$					
a	b	c										
$\leq t$	$\leq 1/8X$	$\leq L$										

12.4 RELIABILITY TEST

12.4.1 STANDARD SPECIFICATIONS FOR RELIABILITY OF LCD MODULE

NO	ITEM	DESCRIPTION
1	High temperature operation	The sample should be allowed to stand at +70°C for 240 hrs
2	Low temperature operation	The sample should be allowed to stand at -20°C for 240 hrs
3	High temperature storage	The sample should be allowed to stand at +80°C for 240 hrs
4	Low temperature storage	The sample should be allowed to stand at -30°C for 240 hrs
5	High temp / humidity test storage	The sample should be allowed to stand at 60°C , 90% RH 240 hrs
6	Thermal shock (not operated)	The sample should be allowed to stand the following 10 cycles of operation: -40°C for 30 minutes ~ +85°C for 30 minutes
7	ESD (Electrostatic Discharge) (not operated)	AIR DISCHARGE ± 12KV CONTACT DISCHARGE ± 8KV

NOTE (1) : THE TEST SAMPLES HAVE RECOVERY TIME FOR 2 HOURS AT ROOM TEMPERATURE BEFORE THE FUNCTION CHECK. IN THE STANDARD CONDITIONS, THERE IS NO DISPLAY FUNCTION NG ISSUE OCCURRED.

12.5 TESTING CONDITIONS AND INSPECTION CRITERIA

For the final test the testing sample must be stored at room temperature for 24 hours, after the tests listed in table 12.5 , standard specifications for reliability have been executed in order to ensure stability .

NO	ITEM	TEST MODEL	INSPECTION CRITERIA
1	Current consumption	Refer To Specification	The current consumption should conform to the product specification.
2	Contrast	Refer TO Specification	After the tests have been executed, the contrast must be larger than half of its initial value prior to the tests.
3	Appearance	Visual inspection	Defect free

12.6 OPERATION

- 12.6.1 Do not connect or disconnect modules to or from the main system while power is being supplied .
- 12.6.2 Use the module within specified temperature ; lower temperature causes the retardation of blinking speed of the display ; higher temperature makes overall display discolor . When the temperature returns to normality , the display will operate normally .
- 12.6.3 Adjust the LC driving voltage to obtain the optimum contrast .
- 12.6.4 Power On Sequence input signals should not be supplied to LCD module before power supply voltage is applied and reaches the specified value . If above sequence is not followed , CMOS LSIs of LCD modules may be damaged due to latch - up problem .
- 13.6.5 Not allowed to inflict any external stress and to cause any mechanical Interference on the bending area of fpc during the tail bending backwards! do not stress fpc and ic on the module!

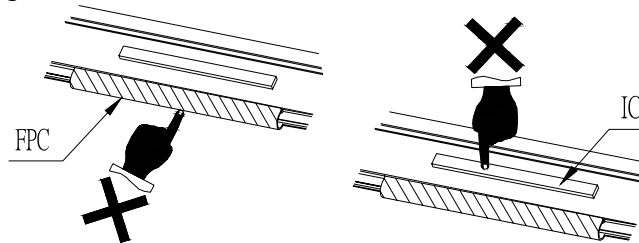

12.7 NOTICE

- 12.7.1 Use a grounded soldering iron when soldering connector I/O terminals . For soldering or repairing , take precaution against the temperature of the soldering iron and the soldering time to prevent peeling off the through-hole-pad .
- 12.7.2 Do not disassemble . EDT shall not be held responsible if the module is disassembled and upon the reassembly the module failed .
- 12.7.3 Do not charge static electricity , as the circuit of this module contains CMOS LSIs. A workman's body should always be static-protected by use of an ESD STRAP . Working clothes for such personnel should be of static-protected material .
- 12.7.4 Always ground the electrically-powered driver before using it to install the LCD module. While cleaning the work station by vacuum cleaner, do not bring the sucking mouth near the module ; static electricity of the electrically-powered driver or the vacuum cleaner may destroy the module .
- 12.7.5 Don't give external shock.
- 12.7.6 Don't apply excessive force on the surface.
- 12.7.7 Liquid in LCD is hazardous substance. Must not lick and swallow. When the liquid is attach to your, skin, cloth etc. Wash it out thoroughly and immediately.
- 12.7.8 Don't operate it above the absolute maximum rating.
- 12.7.9 Storage in a clean environment, free from dust, active gas, and solvent.
- 12.7.10 Store without any physical load.
- 12.7.11 Rewiring: no more than 3 times.